

Product Description

Model EIR508-2xx-T

Documentation Number: EIR508-2xx-T 1713m



707 Dayton Road -- P.O. Box 1040 -- Ottawa, IL 61350 USA

Phone (815) 433-5100 -- General Fax (815) 433-5105

Phone (815) 433-5100 -- **General Fax** (815) 433-5105

Website: www.bb-elec.com

Sales e-mail: orders@bb-elec.com -- **Fax** (815) 433-5109

Technical Support e-mail: support@bb.elec.com -- **Fax** (815) 433-5104

European Headquarters

B&B Electronics

Westlink Commercial Park -- Oranmore, Co. Galway, Ireland

Phone +353 91-792444 -- **Fax** +353 91-792445

Website: www.bb-europe.com

Sales e-mail: sales@bb-europe.com

Technical Support e-mail: support@bb-europe.com

© 2008 B&B Electronics Mfg. Co. Inc. - Revised February 2008

Eight Port Managed Industrial Ethernet Switches

User Manual

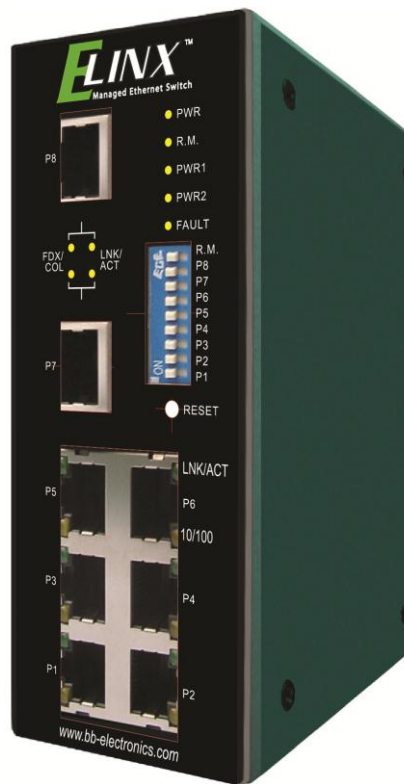

FCC

This Equipment has been tested and found to comply with the limits for a Class-A digital device, pursuant to Part 15 of the FCC rules. These limits are designed to provide reasonable protection against harmful interference.

This equipment generates uses and can radiate radio frequency energy and, if not installed and used in accordance with the instructions, may cause harmful interference to radio communications. However, there is no guarantee that interference will not occur in a particular installation. If this equipment does cause harmful interference to radio or television reception, which can be determined by turning the equipment off and on, the user is encouraged to try to correct the interference by one or more of the following measures:

- Reorient or relocate the receiving antenna.
- Increase the separation between the equipment and receiver.
- Connect the equipment into an outlet on a circuit different from that to which the receiver is connected.
- Consult the dealer or an experienced radio/TV technician for help.

CE

This is a Class-A product. In a domestic environment this product may cause radio interference in which case the user may be required to take adequate measures.

Content

Introduction	8
Features	8
Package Contents	9
Hardware Description.....	10
Physical Dimension (W x H x D)	10
Front Panel.....	10
Reset Button	10
Bottom View	11
DIP-switch	12
LED Indicators.....	14
Ports	15
Cabling	17
Wiring the Power Inputs	17
Wiring the Fault Alarm Contact	18
Mounting Installation.....	19
DIN-Rail Mounting.....	19
Panel Mounting	21
Hardware Installation.....	22

Installation Steps	22
Network Application	23
X-Ring Application.....	23
Coupling Ring Application	24
Dual Homing Application	25
Web-Based Management	26
About Web-based Management	26
Preparing for Web Management	26
System Login.....	26
Port status	28
Single Port Information	28
Port Statistics	29
Port Control	30
Switch Setting.....	31
Port Mirroring.....	32
VLAN configuration	33
Port-based VLAN	33
802.1Q VLAN	36
Alert	39

Email Alert Configuration.....	39
Event Configuration.....	41
Power Alarm Configuration.....	42
IP Configuration.....	43
SNTP Configuration	44
IP Security	47
RSTP Configuration	48
System Configuration	48
Per Port Configuration.....	49
X-Ring	51
QoS Configuration.....	52
IGMP	55
Security Manager	56
SNMP Configuration.....	56
System Options.....	57
Community strings.....	57
Trap Manager.....	58
Configuration Backup.....	58
TFTP Restore Configuration.....	58
TFTP Backup Configuration	59
TFTP Update Firmware.....	59

Factory Default	60
System Reboot.....	60
Save Configuration.....	61
Rate Control	61
System Log	62
System Log	62
Event Configuration	63
Trouble shooting.....	65
Technical Specifications	66

Introduction

The Elinx EIR508 series of Industrial Managed Ethernet Switches provide powerful functionality in a small package. Designed for industrial applications, these switches are highly reliable

Features

- Conforms to IEEE 802.3 10Base-T, 802.3u 100Base-TX/100Base-FX
- 6 10/100TX and 2 100FX ports (fiber models only)
- 8 10/100TX ports (all copper model)
- Auto MDI/MDI-X
- Store-and-Forward switching architecture
- Wide-range redundant power inputs
- DIN rail and panel mount design
- 2K MAC address table
- Web management GUI
- 4 priority queues per port
- IEEE 802.3x flow control
 - Flow control with full-duplex
 - Back pressure with half-duplex
- Class of service
- IGMP with Query mode for multi media application
- Ingress packet filter and egress rate limit.
- SNTP/SMTP
- Port mirror for TX or TX and RX packet.
- Alarm Relay Output
- X-Ring Redundant Ring Technology
- Reverse Polarity Protection on power inputs
- 1M bits Embedded memory
- Port based VLAN / 802.1 Q Tag VLAN
- IEEE 802.1p class of service and provide port base, Tag base and Type of service priority method

- DHCP client
- SNMP, Web Management, RMON
- TFTP firmware update, system configuration, restore, and backup.

Package Contents

- One Industrial Ethernet Switch
- One Quick Start Guide
- One CD ROM containing users manual
- One DIN-Rail Clip (attached to the switch)
- One panel mount plate and six screws

If any item is damaged or missing, contact B&B Electronics.

Hardware Description

Physical Dimension (W x H x D)

2.3 x 5.7 x 4.3 in (5.8 x 14.5 x 10.9 cm)

Front Panel

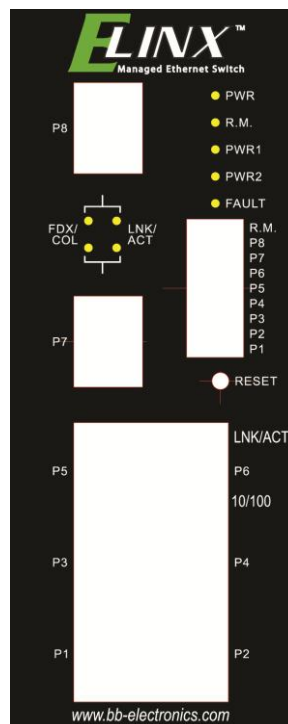

Front Panel of the industrial switch

Reset Button

The reset button is used to restart the reboot the switch or restore it to the factory default configuration.

- **Restart:** Press the button for 2 seconds and release.
- **Set to factory default value:** Press the button for 5 seconds and release.

Bottom View

The bottom panel of the industrial switch has one terminal block connector within two DC power inputs and fault relay contacts.

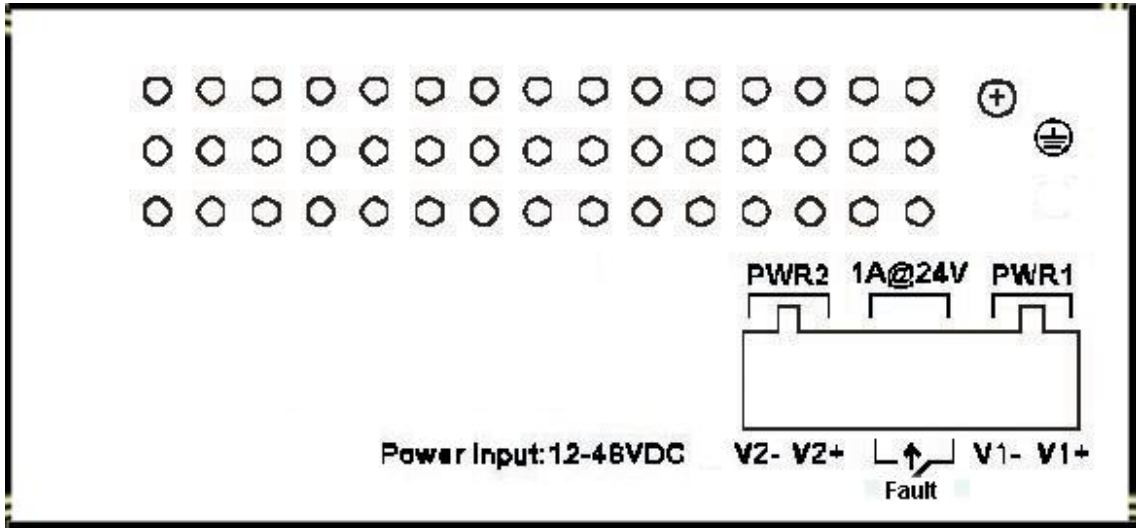

Bottom Panel of the industrial switch

DIP-switch

The nine position DIP-switch is used to configure the relay alarm ring master mode. The default value for each position is **OFF**. Software configuration is also required for the alarm relay. The alarm relay contacts are normally open.

DIP Switch No	Status	Description
1	OFF	Disable port 1 Alarm
	ON	Enable port 1 Alarm.
2	OFF	Disable port 2 Alarm
	ON	Enable port 2 Alarm.
3	OFF	Disable port 3 Alarm
	ON	Enable port 3 Alarm.
4	OFF	Disable port 4 Alarm
	ON	Enable port 4 Alarm.
5	OFF	Disable port 5 Alarm
	ON	Enable port 5 Alarm.
6	OFF	Disable port 6 Alarm

	ON	Enable port 6 Alarm.
7	OFF	Disable port 7 Alarm
	ON	Enable port 7 Alarm.
8	OFF	Disable port 8 Alarm
	ON	Enable port 8 Alarm.
9	OFF	Disable the ring master function
	ON	Enable the switch as the ring master in the X-Ring group

[NOTE] Restart the switch after the X-Ring DIP switch is set.

[NOTE] The Alarm Relay Output requires software configuration in addition to the DIP Switch setting.

LED Indicators

There are 7 diagnostic LEDs located on the front panel. They provide real time status information.

LED	Status	Meaning
Power	Green	The switch is on
	Off	The switch is off or no power input is available.
Power 1	Green	Power source 1 is available.
	Off	Power source 1 is not available.
Power 2	Green	Power source 2 is available.
	Off	Power source 2 is not available.
Fault	Yellow	Power failure or port failure (See Alarm setting for operational details)
	Off	Normal Operation
R.M. (Ring Master)	Green	The switch is the master of an X-Ring group
	Off	The switch is not the master of an X-Ring group
LNK/ACT (Port 7 & 8)	Green	The port is linked
	Blinks	The port is transmitting or receiving
	Off	No device attached
FDX/COL (Port 7 & 8)	Yellow	The port is operating in full-duplex mode
	Blinks	Data Packet Collision
	Off	The port in half-duplex mode or is not connected to a device

Ports

■ RJ-45 ports

There are 5 (or 8) 10/100Mbps auto-sensing ports for 10Base-T or 100Base-TX device connection. The ports are auto-sensing and auto MDI/MDIX.

■ RJ-45 Pin Assignments

Pin Number	Assignment
1	Tx+
2	Tx-
3	Rx+
6	Rx-

All copper ports on this switch support automatic MDI/MDI-X operation. Straight-through cables can be used for all network connections. In straight-through cable, pins 1, 2, 3, and 6, at one end of the cable, are connected straight through to pins 1, 2, 3 and 6 at the other end of the cable. The table below shows the 10BASE-T/100BASE-TX MDI and MDI-X port pin outs.

Pin MDI-X	Signal Name	MDI Signal Name
1	Receive Data plus (RD+)	Transmit Data plus (TD+)
2	Receive Data minus (RD-)	Transmit Data minus (TD-)
3	Transmit Data plus (TD+)	Receive Data plus (RD+)
6	Transmit Data minus (TD-)	Receive Data minus (RD-)

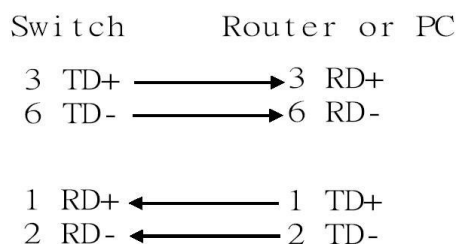

Straight Through Cable Schematic

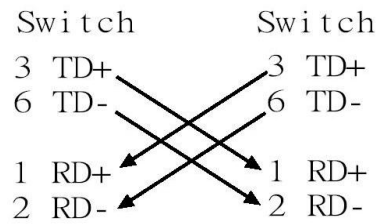

Cross Over Cable Schematic

■ Fiber Port (Fiber Models Only)

There are two 100Base-FX ports. Depending on the model, the fiber ports have either SC or ST type connectors and use multi-mode (2Km) or single mode (30Km) cable.

Connect the fiber ports as described below.

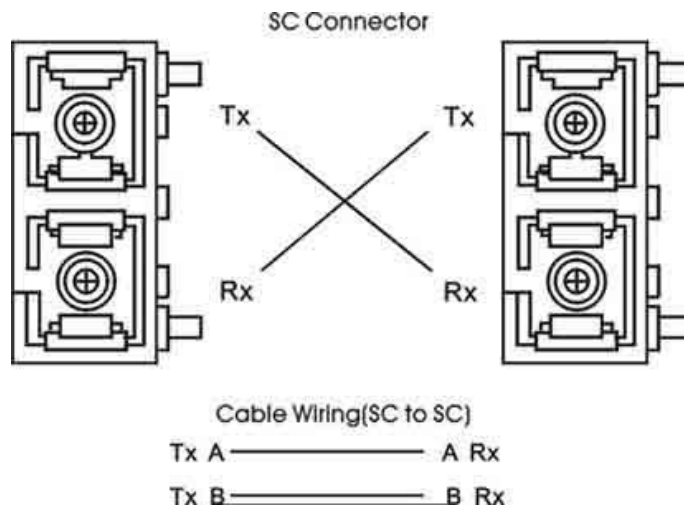

ATTENTION



This is a Class 1 Laser/LED product. Do not stare into the Laser/LED Beam.

Cabling

- Use Category 5 cabling for RJ-45 port connections. The cable must be less than 328 ft (100 meters) long.
- Use 9/125 um cable for **single-mode** fiber. Distances up to **30 Kilometers** are supported.
- Use 50/125 or 62.5/125 cable for **multi-mode** fiber. Distances up to **2Km** are supported.

Wiring the Power Inputs

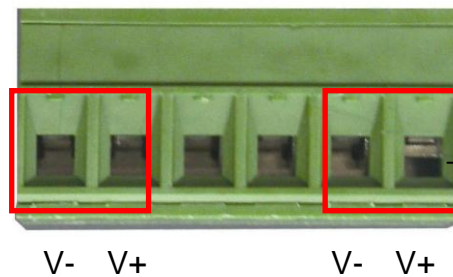

1. Insert the positive and negative wires into the V+ and V- connector on the terminal block connector.

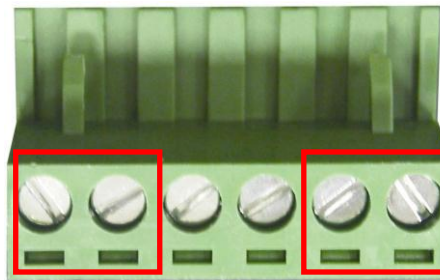

2. Tighten the wire-clamp screws.

[NOTE] Use 12~ 24 AWG wire.

Wiring the Fault Alarm Contact

The fault alarm contact is located in the middle of terminal block connector as shown below. Insert the wires and set the Dipswitch to “ON”. When a power source fails or a link fault occurs the relay contacts will close.

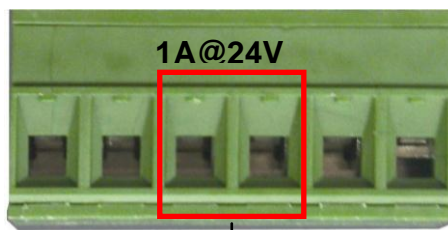

Insert the wires into the fault alarm contact

[NOTE] Use 12~ 24 AWG wire.

[NOTE] Relay contacts are normally open.

[NOTE] The Relay Alarm also requires software configuration. Refer to the Web Based Management Alert Section.

Mounting Installation

DIN-Rail Mounting

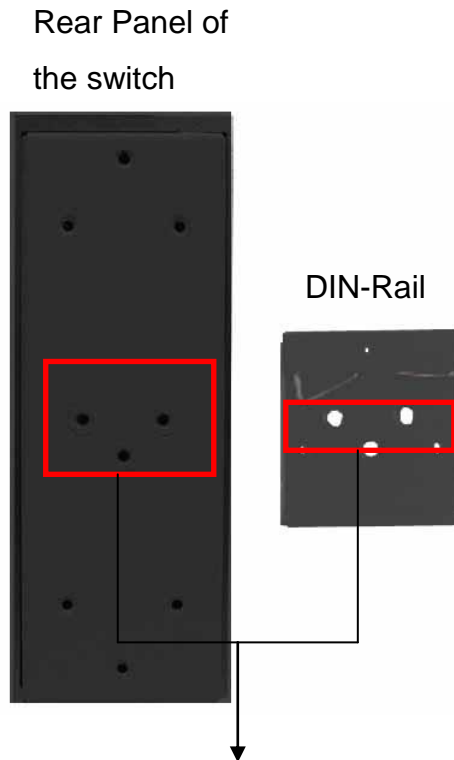

1. Use the screws to screw the DIN-Rail to the industrial switch
2. To remove the DIN-Rail, reverse the step 1.

1. First, insert the top of DIN-Rail into the track.

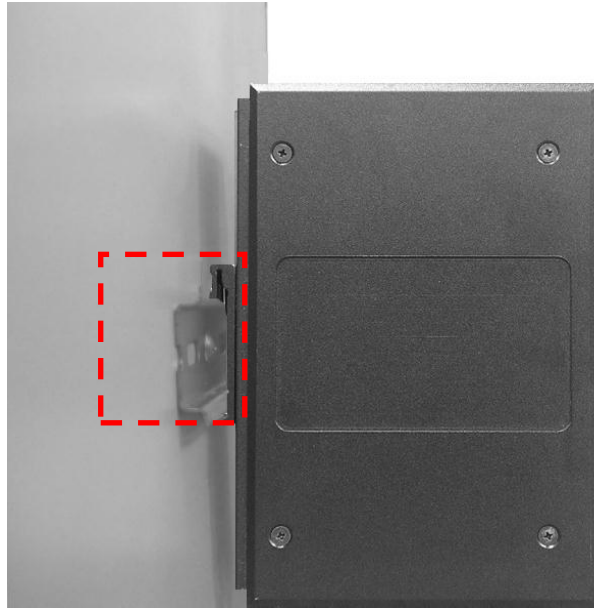

2. Then, lightly push the DIN-Rail into the track.

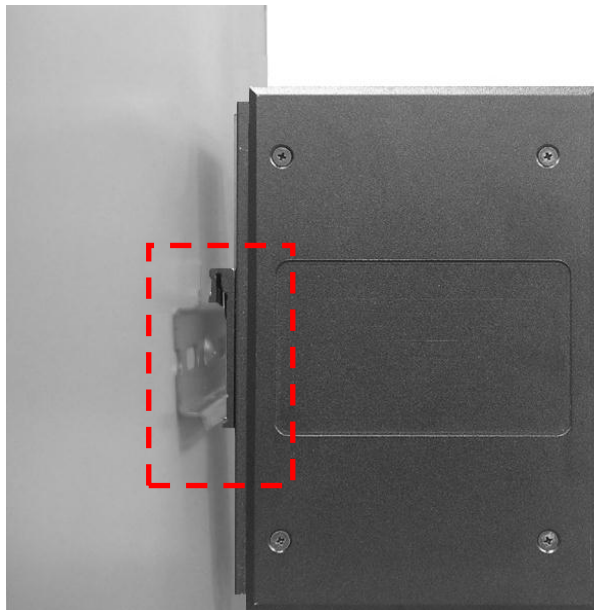

3. Ensure the DIN-Rail is tightly secured on the track.
4. To remove the industrial switch from the track, reverse steps above.

Panel Mounting

1. Remove the DIN-Rail.
2. Place the panel mount plate on the rear panel of the industrial switch.
3. Attach the plate with the screws provided.
4. Use the hook holes at the corners of the plate to mount the switch to the panel.
5. To remove the panel mount plate, reverse steps above.

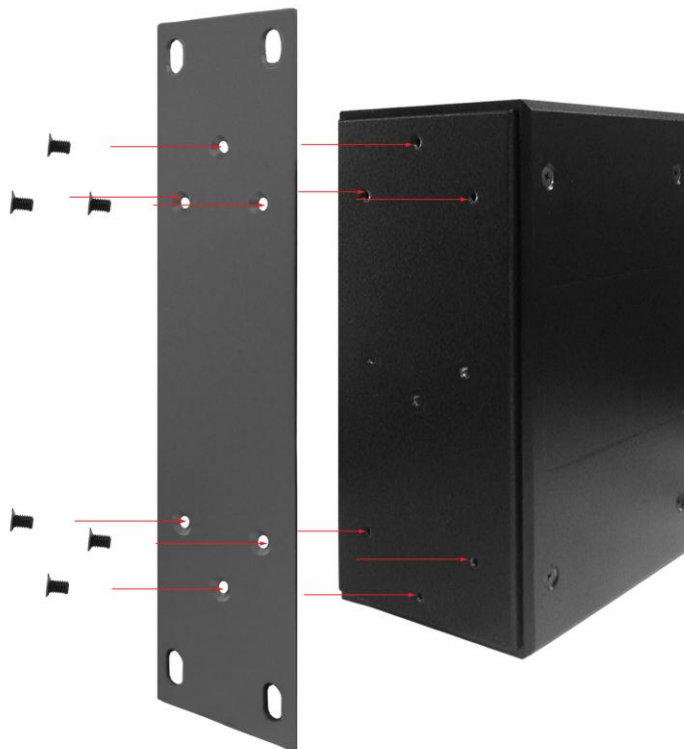

Hardware Installation

Installation Steps

1. Unpack the switch
2. Ensure the DIN-Rail is tightly screwed to the switch. If it is not, refer to **DIN-Rail Mounting** section. If panel mounting is desired, refer to **Panel Mounting Section**.
3. Mount the switch.
4. Apply power to the switch. The power LED will light up.
5. Connect CAT 5 cables to the industrial switch's RJ-45 ports and the network devices.

[NOTE] If the network devices do not support MDI/MDI-X, a crossover cable will be required.

6. (Fiber Models Only) Connect the fiber optic cables to the industrial switch and the network devices. Ensure that the switch's fiber optic transmitter is connected to the network devices receiver and vice versa.
7. When all the connections are made and the LED's show normal indication, the installation is complete.

Network Application

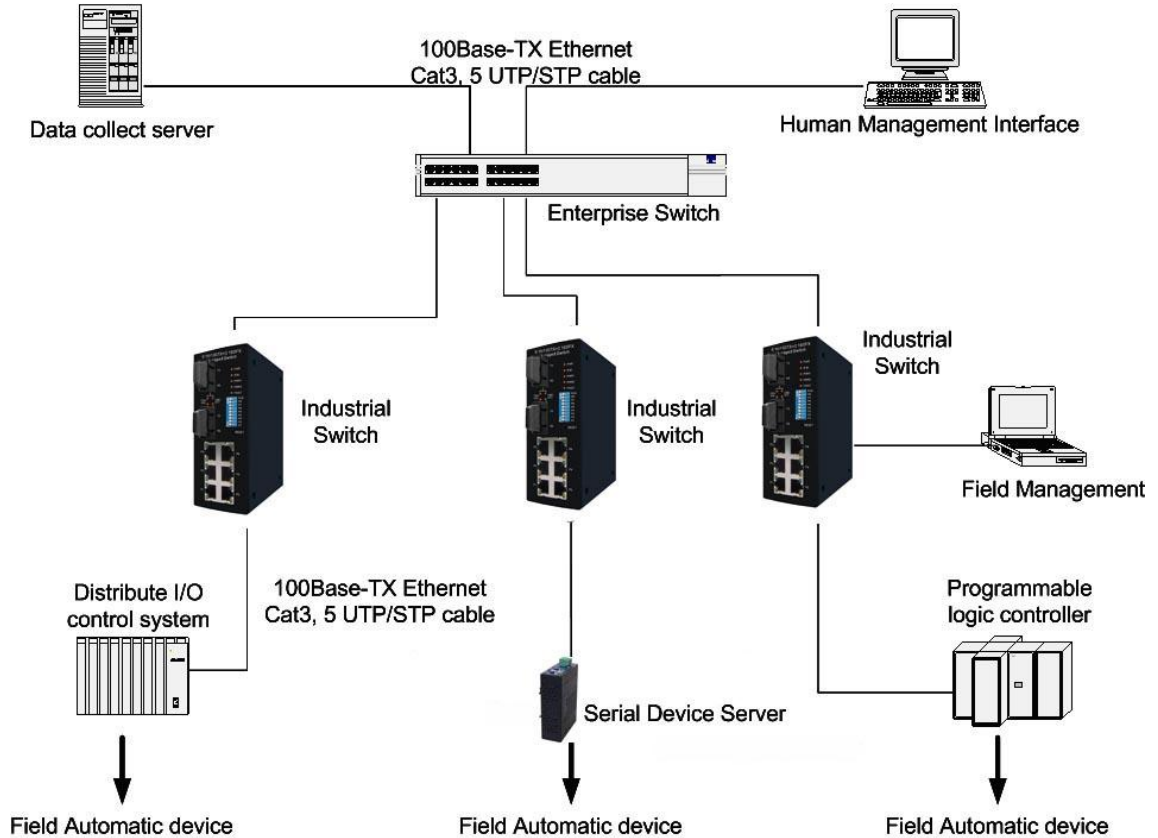

X-Ring Application

The EIR508 series of Industrial Switches incorporate the X-Ring Protocol to ensure network reliability and system restoration within 300 ms in the event of a connection failure. The X-Ring algorithm is similar to the spanning tree protocol (STP) algorithm but it has faster recovery time. The following figure below is an example of an X-Ring application.

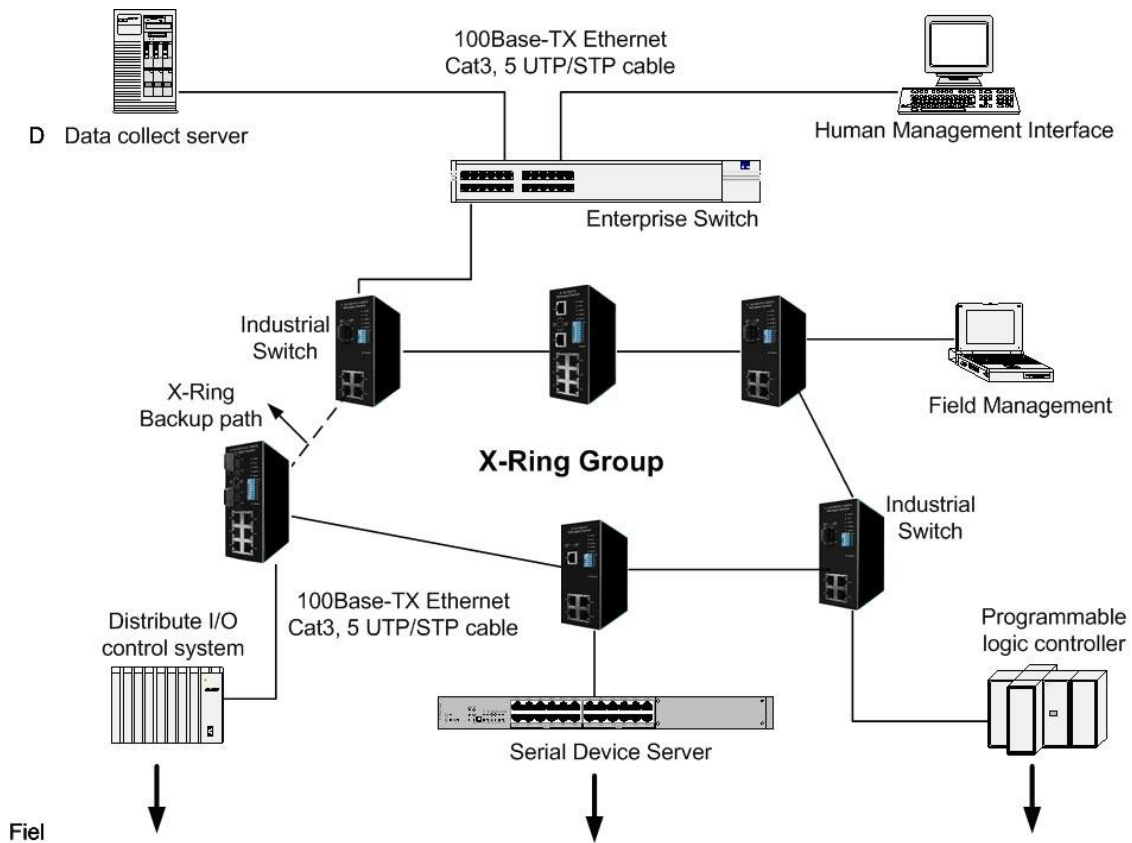

Coupling Ring Application

If the network has more than one X-Ring group, the coupling ring function is used to connect them and add redundancy. This ensures that transmissions between the two ring groups will not fail. The figure below is an example of the coupling ring application.

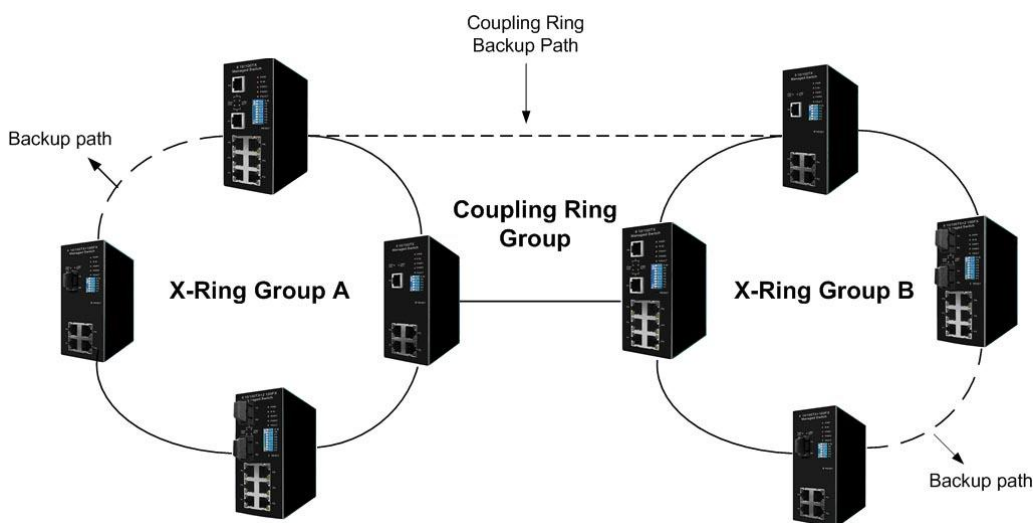

Dual Homing Application

The Dual Homing function is used to prevent a connection loss between the X-Ring group and the upper level/core switch. Assign a port in each X-ring group to be the Dual Homing ports. The Dual Homing function can only be used when the X-Ring function is active. Each X-Ring group can have one Dual Homing port.

[NOTE] In the Dual Homing architecture, the upper level switches must have Rapid Spanning Tree protocol enabled.

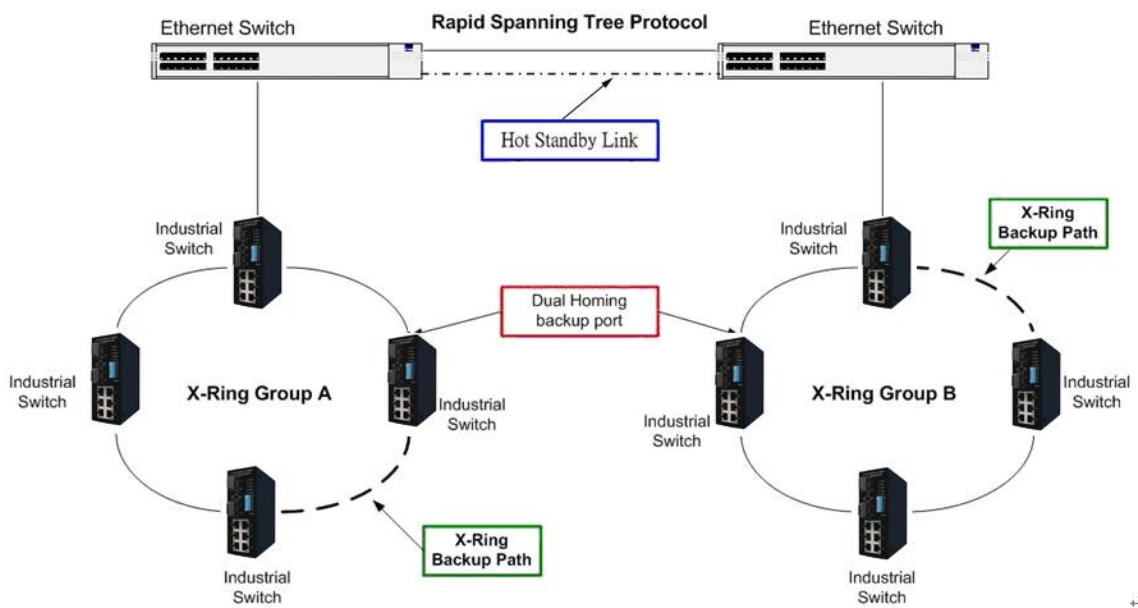

Web-Based Management

About Web-based Management

The switch has an embedded HTML web site residing in flash memory. This site offers advanced management features and allows the switch to be configured from anywhere on the network.

The web site is designed for Internet Explorer 6.0 and uses Java Applets to reduce bandwidth consumption, enhance access speed, and present an intuitive user interface.

Preparing for Web Management

Before using web management, install the industrial switch on the network and verify that a PC on the local network can connect with the switch through the web browser. The default IP Address, Subnet Mask, Username and Password is listed below:

- IP Address: **192.168.16.1**
- Subnet Mask: **255.255.255.0**
- Default Gateway: **192.168.16.254**
- User Name: **root**
- Password: **root**

System Login

1. Launch Internet Explorer on the PC.
 2. Enter "http:// "+" the IP address of the switch", in the address window and then Press "Enter".
 3. The login screen will appear.
 4. Enter the user name and password.
- Press "Enter" or "OK", the home screen will appear.

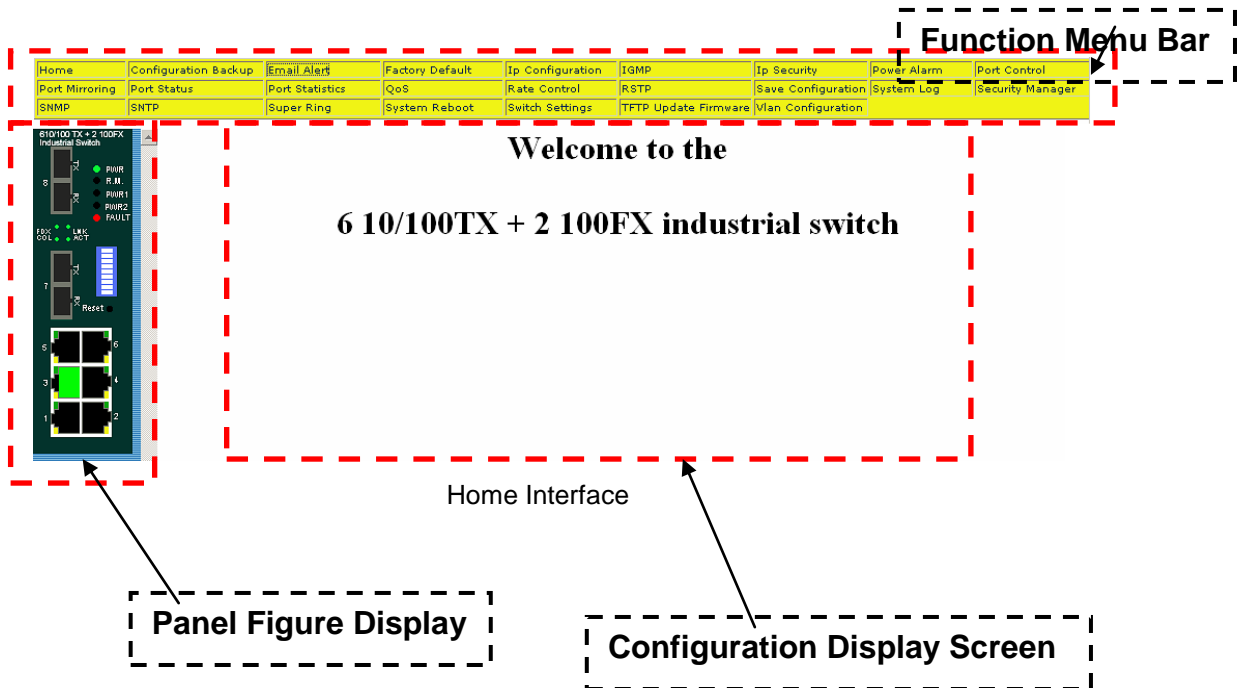

Port status

Shows the status of each port

- **Port:** Displays the port number
- **Type:** Displays the speed and mode, ex: 100TX = 100Mbps
- **Link:** Displays the ports status (up or down)
- **State:** Displays the ports status (disabled or enabled). Unlinked is displayed as “off ”
- **Negotiation:** Displays the auto negotiation mode (auto or forced).
- **Speed Duplex:** Displays the port connection speed. “Config” is the configured value. “Actual” is the current value.

Flow Control: Displays the flow control status as “Symmetric” or “Asymmetric” in full mode. “Disable” means that flow control is not enabled “Config” indicates that the value is user configured. “Actual” is the current value of the port.

Port Status								
Port	Type	Link	State	Negotiation	Speed Duplex		Flow Control	
					Config	Actual	Config	Actual
Port.01	100TX	Down	Enable	Auto	100 Full	N/A	Symmetric	N/A
Port.02	100TX	Down	Enable	Auto	100 Full	N/A	Symmetric	N/A
Port.03	100TX	Down	Enable	Auto	100 Full	N/A	Symmetric	N/A
Port.04	100TX	Down	Enable	Auto	100 Full	N/A	Symmetric	N/A
Port.05	100TX	Up	Enable	Auto	100 Full	100 Full	Symmetric	Symmetric
Port.06	100TX	Down	Enable	Auto	100 Full	N/A	Symmetric	N/A
Port.07	100FX	Down	Enable	Force	100 Full	N/A	Asymmetric	N/A
Port.08	100FX	Down	Enable	Force	100 Full	N/A	Asymmetric	N/A

Port Status interface

Single Port Information

Click the desired port on the Panel figure. The single port information window will display the current port information.

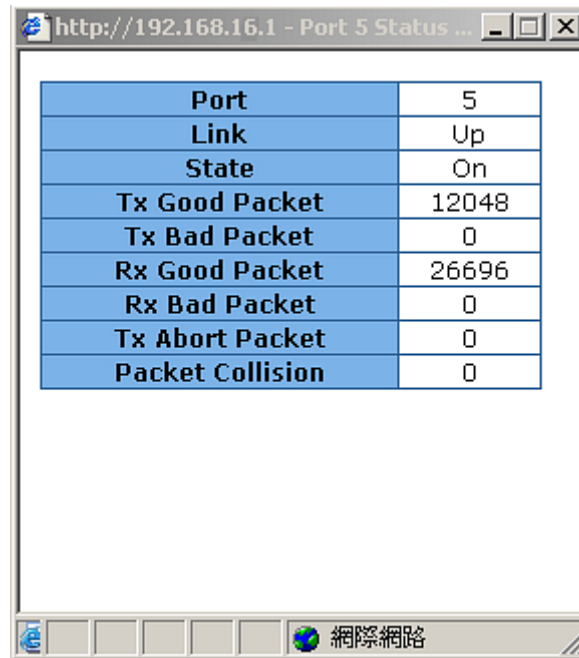

Port	5
Link	Up
State	On
Tx Good Packet	12048
Tx Bad Packet	0
Rx Good Packet	26696
Rx Bad Packet	0
Tx Abort Packet	0
Packet Collision	0

Port information interface

Port Statistics

Displays port statistics.

- Click button to reset.

Port Statistics

Port	Type	Link	State	Tx Good Packet	Tx Bad Packet	Rx Good Packet	Rx Bad Packet	Tx Abort Packet	Packet Collision
Port.01	100TX	Down	Enable	0	0	0	0	0	0
Port.02	100TX	Down	Enable	0	0	0	0	0	0
Port.03	100TX	Down	Enable	0	0	0	0	0	0
Port.04	100TX	Down	Enable	0	0	0	0	0	0
Port.05	100TX	Up	Enable	12736	0	28043	0	0	0
Port.06	100TX	Down	Enable	0	0	0	0	0	0
Port.07	100FX	Down	Enable	0	0	0	0	0	0
Port.08	100FX	Down	Enable	0	0	0	0	0	0

Port Statistics Interface

Port Control

Use to set up the port.

- Select the port by scrolling down the **Port** column. The current port information will be displayed in the table below.
- State:** Enables or disables the port.
- Negotiation:** Sets the negotiation mode to Auto, Nway (specify the speed/duplex of the port and enable auto-negotiation), or Forced.
- Speed:** Sets the transmit speed of the port
- Duplex:** Sets the port to full-duplex or half-duplex
Flow control: Sets flow control function to **Symmetric** or **Asymmetric** in Full Duplex mode (The default value is **Disable**)
- Click button to apply configuration
- Select the port again to verify the configuration.

Port Configuration

Port	State	Negotiation	Speed	Duplex	Flow Control
Port.01					
Port.02	Enable	Auto	100	Full	Disable
Port.03					
Port.04					

Apply Help

Port	Type	Link	State	Negotiation	Speed Duplex		Flow Control		Group ID	
					Config	Actual	Config	Actual		
Port.01	100TX	Down	Enable	Auto	100	Full	N/A	Disable	N/A	N/A

Port Control interface

Switch Setting

Used to assign the system name, location and to view system information

- **System Name:** Assigns a name to the switch. The maximum length is 64 bytes
- **System Location:** Assigns a physical location for the switch. The maximum length is 64 bytes
- **System Description:** Displays the description of switch. This is read only and cannot be modified
- **Firmware Version:** Displays the firmware version
- **Kernel Version:** Displays the kernel software version
- **Hardware version:** Display the hardware version
- **MAC Address:** Display the unique hardware address assigned by manufacturer (this value is different for each switch)

Port Mirroring

Port mirroring is a method to monitor traffic in switched networks. This is accomplished by mirroring the traffic going in and out of the monitored ports to a specifically designated port (the mirror port).

1. **Port Mirroring Mode:** Sets the mirror mode. Select disable to disable port mirroring. Select TX to monitor data being transmitted by a port. Select both to monitor port data being transmitted and received by a port. The default value is “Disable”.
2. **Analysis Port:** This is the port used to see all monitored port traffic (This port can be connected to a LAN analyzer or Netxray).
3. **Monitor Port:** Check the box to monitor the port. Up to 4 ports can be designated as monitor ports.
4. Click

Port Mirroring

Port Mirroring Mode :

Analysis Port :

Monitor Port	State
Port.01	<input type="checkbox"/>
Port.02	<input type="checkbox"/>
Port.03	<input type="checkbox"/>
Port.04	<input type="checkbox"/>
Port.05	<input type="checkbox"/>
Port.06	<input type="checkbox"/>
Port.07	<input type="checkbox"/>
Port.08	<input type="checkbox"/>

Port Mirroring interface

[NOTE] If the configuration is not saved, it will be lost when the switch is powered off.

VLAN configuration

A Virtual LAN (VLAN) can be thought of as a broadcast domain that exists within a switch or a defined set of switches. By grouping switch ports into VLANs, traffic flooding is limited since devices can only communicate directly with devices belonging to the VLAN. Creating a VLAN from a switch is the logical equivalent of reconnecting a group of devices to another Layer 2 switch. However, the network devices retain their same physical connection. The EIR508 series switches support port-based and 802.1Q (tagged-based) VLAN. In the default configuration, the VLAN option is disabled.

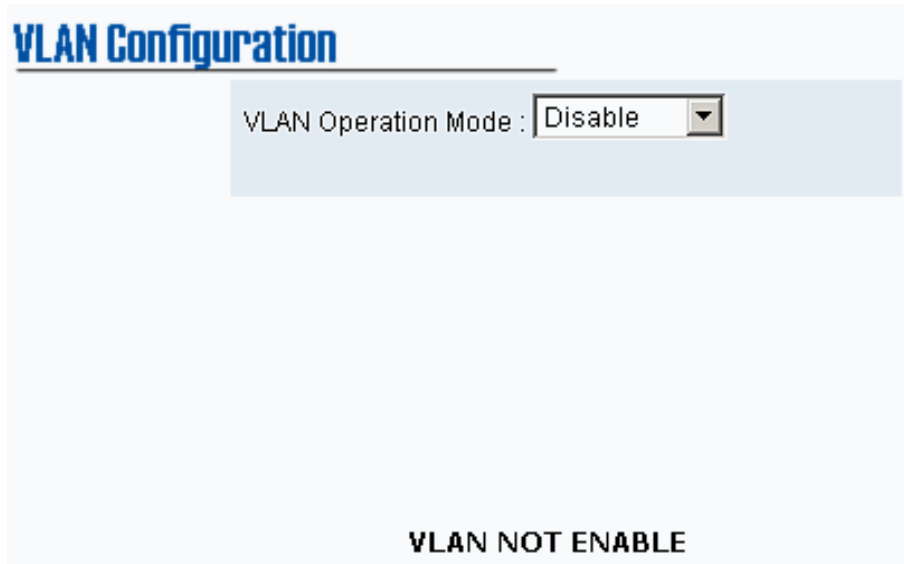

VLAN Configuration interface

Port-based VLAN

With port-based VLAN, the port is assigned to a VLAN. Therefore, all devices attached to a given port should be members of the same VLAN. As with other VLAN configurations, the packets forwarded using this method do not leak into other VLAN domains on the network. After the port has been assigned to a VLAN, devices on the port cannot send to or receive from devices in other VLANs without the intervention of another layer 3 device or the ability to tag the data packet with a specific PVID.

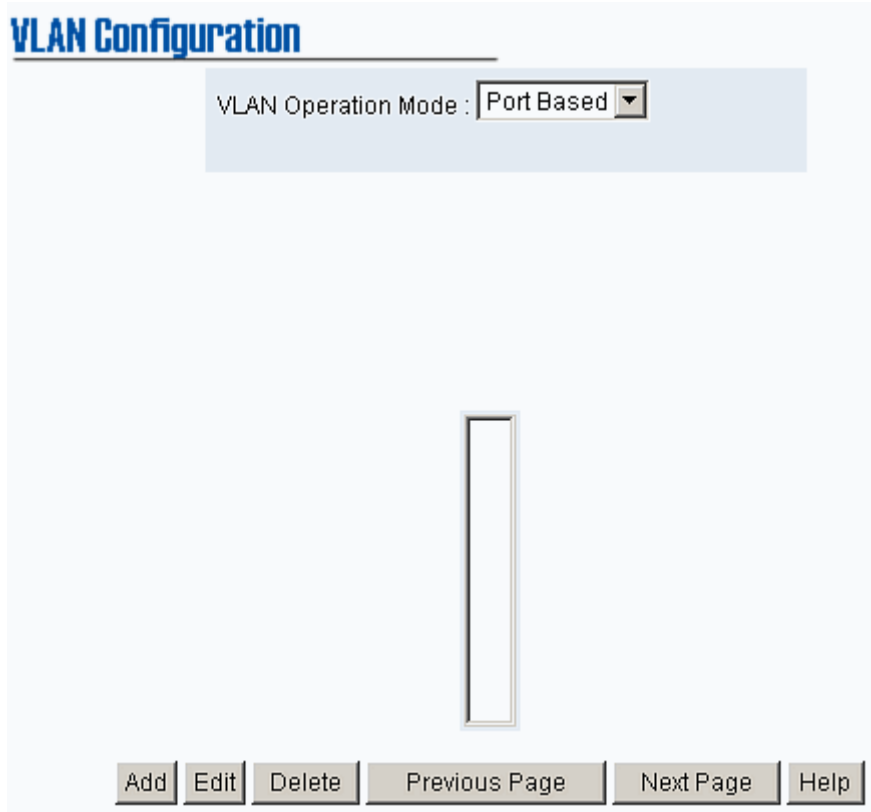

VLAN – PortBase interface

1. Click **Add** to add a new VLAN group. The EIR508 series supports up to 64 VLAN
2. Enter Group name, VLAN ID and select the members of VLAN group
3. Click **Apply**

VLAN Configuration

VLAN Operation Mode :

Group Name

VLAN ID

Port.01
Port.02
Port.03
Port.04
Port.05
Port.06
Port.07
Port.08

VLAN—PortBase Add interface

4. The VLAN group will be displayed after it is clicked
5. Click to view the next VLAN Group
6. Use the button to delete unwanted VLANs
7. Use to modify existing VLANs

[NOTE] If the configuration is not saved, it will be lost when the switch is powered off

802.1Q VLAN

Tagged-based VLAN is an IEEE 802.1Q specification which allows VLANs to be created across devices from different vendors. IEEE 802.1Q VLAN uses a technique to insert a “tag” into the Ethernet frame. The tag contains a VLAN Identifier (VID).

When the 802.1Q VLAN is enabled, all ports on the switch belong to a default VLAN (VID 1). The default VLAN can't be deleted. The EIR508 series will support up to 64 VLAN groups.

VLAN Configuration

VLAN Operation Mode : 802.1Q

Management Vlan ID : 0

Basic **Port VLAN ID**

DEFAULT__1

802.1q VLAN interface

■ Basic

1. Click
2. **Management VLAN ID:** Used for Remote Management Security. When this option is selected, remote management is only available to the members of the indicated VLAN Group. Enter the specific VALN ID

number in Management VLAN ID column, check the box, and click the apply button. Example: If the management VLAN ID is 101 and the VLAN Group ID 101 includes ports 1, 2, and 4, only ports 1, 2, and 4 can perform remote management functions on the switch. If a port is in multiple VLAN groups, it can still perform management functions as long as one VLAN group ID is equal to the Management VLAN ID.

3. **Group Name:** Assign a name for the new VLAN
4. **VLAN ID:** Enter a VLAN ID (2~4094). The default is 1
5. From the available ports box, select ports to add to the VLAN Group and click the button

VLAN Configuration

VLAN Operation Mode : 802.1Q

Management Vlan ID : 0

Basic **Port VLAN ID**

Group Name

VLAN ID

Port.01
Port.02
Port.03
Port.04
Port.05
Port.06
Port.07
Port.08

802.1q VLAN –Add interface

6. Click to bring up the configuration interface.

VLAN Configuration

VLAN Operation Mode : 802.1Q

Management Vlan ID : 0

VLAN Name	V001	
VLAN ID	2	
UnTag Member		
Port.01	Untag	Port.02 Untag

7. Select outgoing frames as VLAN tagged or untagged and then click

■ **Port VID:** Configure port VID settings

1. **Port VLAN ID:** Enter the port VLAN ID

2. Click

3. To reset back to default value, click button

VLAN Configuration

VLAN Operation Mode : 802.1Q

Management Vlan ID : 0

Basic

Port VLAN ID

Port	Port VLAN ID
Port.01	
Port.02	
Port.03	
Port.04	

Port	VLAN ID
Port.01	1

802.1q VLAN – Port VLAN ID interface

[NOTE] If the configuration is not saved, it will be lost if the switch is powered off.

Alert

Email Alert Configuration

When a specified event occurs, the switch will send an alert email.

- **Email Alert:** Enables or disable the function
- **SMTP Server IP Address:** Enter the mail server IP address
- **Authentication:** Mark the check box to enable and configure the email account and password for authentication

- **Mail Account:** Enter the email address used to send the alert. Ex: Switch@123.com. This account must exist on the mail server.
- **Password:** The email account password
- **Confirm Password:** Confirm the password
- **E-mail Address of Recipient 1 ~ 4:** Enter up to 4 e-mail accounts to receive the alert
- Click

Alert

Email Alert Configuration
Event Configuration
Power Alarm Configuration

E-mail Alert: ▼

SMTP Server IP Address :	<input type="text" value="0.0.0.0"/>
Sender's Email Address :	<input type="text"/>
<input type="checkbox"/> Authentication	
Mail Account :	<input type="text"/>
Password :	<input type="text"/>
Confirm Password :	<input type="text"/>
Email of Recipient 1 :	<input type="text"/>
Email of Recipient 2 :	<input type="text"/>
Email of Recipient 3 :	<input type="text"/>
Email of Recipient 4 :	<input type="text"/>

Email Alert Configuration interface

Event Configuration

- **System event selection:** 4 selections – Device cold start, Power status, SNMP Authentication Failure, and X-Ring topology changes. Mark the checkbox to select the event. When the selected events occur, the system will send out an email alert.
 - **Device cold start:** Sends an alert when the device executes a cold start.
 - **Power status:** Sends an alert when the power status changes. (i.e. power source 1 removed).
 - **SNMP Authentication Failure:** Sends an alert when an SNMP authentication failure occurs.
 - **X-Ring topology change:** Sends an alert when X-Ring topology has changes.
- **Port event selection:** An e-mail alert can be sent for port specific events. Three selections are available: Link UP, Link Down, and Link UP & Link Down.
 - **Link UP:** Sends an alert when the link comes up.
 - **Link Down:** Sends an alert when the port goes down.
 - **Link UP & Link Down:** Sends an alert when the link goes down and comes up.
- Click

Alert

Email Alert Configuration **Event Configuration** **Power Alarm Configuration**

System event selection

Device cold start Power status
 SNMP Authentication Failure X-ring topology change

Port event selection

Port.01	Disable	Port.02	Disable
Port.03	Disable	Port.04	Disable
Port.05	Disable	Port.06	Disable
Port.07	Disable	Port.08	Disable

Event Configuration interface

Power Alarm Configuration

The power alarm enables the relay alarm.

- Mark the check box and click the button

Alert

Email Alert Configuration **Event Configuration** **Power Alarm Configuration**

Power1 Power2

Power Alarm interface

IP Configuration

- **DHCP Client:** Use to enable or disable the DHCP client function. When the DHCP client function is enabled, the industrial switch will be assigned an IP address from the network DHCP server. After the “Apply” button is clicked, dialog box will indicate that the user that when the DHCP client is enabled, the current IP will lost and the new IP must be looked up on the DHCP server. The switch’s MAC Address will be required to look up the new IP Address on the DHCP Server. To cancel the DHCP client function, click “cancel”.
- **IP Address:** Assign a static IP address. This is not required if DHCP Client is enabled. The default IP is 192.168.16.1.
- **Subnet Mask:** Assign the subnet mask of the IP address. This is not required if the DHCP Client is enabled.
- **Gateway:** Assign the network gateway. The default gateway is 192.168.16.254.
- Click

IP Configuration	
DHCP Client :	Disable ▼
IP Address	192.168.16.1
Subnet Mask	255.255.255.0
Gateway	192.168.16.254
<input type="button" value="Apply"/> <input type="button" value="Help"/>	

IP configuration interface

SNTP Configuration

SNTP (Simple Network Time Protocol) allows the switch to synchronize its time with an SNTP Server.

- **SNTP Client:** Enables or Disable SNTP
- **Daylight Saving Time:** Enables or disables daylight saving time. When enabled, the daylight saving time period must be entered.
- **UTC Time zone:** Used to calculate local time. Set the switch location time zone.

Local Time Zone	Conversion from UTC	Time at 12:00 UTC
November Time Zone	- 1 hour	11am
Oscar Time Zone	-2 hours	10 am
ADT - Atlantic Daylight	-3 hours	9 am
AST - Atlantic Standard EDT - Eastern Daylight	-4 hours	8 am
EST - Eastern Standard CDT - Central Daylight	-5 hours	7 am
CST - Central Standard MDT - Mountain Daylight	-6 hours	6 am
MST - Mountain Standard PDT - Pacific Daylight	-7 hours	5 am
PST - Pacific Standard ADT - Alaskan	-8 hours	4 am

Daylight		
ALA - Alaskan Standard	-9 hours	3 am
HAW - Hawaiian Standard	-10 hours	2 am
Nome, Alaska	-11 hours	1 am
CET - Central European FWT - French Winter MET - Middle European MEWT - Middle European Winter SWT - Swedish Winter	+1 hour	1 pm
EET - Eastern European, Russia Zone 1	+2 hours	2 pm
BT - Baghdad, Russia Zone 2	+3 hours	3 pm
ZP4 - Russia Zone 3	+4 hours	4 pm
ZP5 - Russia Zone 4	+5 hours	5 pm
ZP6 - Russia Zone 5	+6 hours	6 pm
WAST - West Australian Standard	+7 hours	7 pm
CCT - China Coast, Russia Zone 7	+8 hours	8 pm
JST - Japan Standard, Russia Zone 8	+9 hours	9 pm
EAST - East Australian Standard GST	+10 hours	10 pm

Guam Standard, Russia Zone 9		
IDLE - International Date Line NZST - New Zealand Standard NZT - New Zealand	+12 hours	Midnight

- **SNTP Sever IP:** Enter the IP address of the SNTP server
- **Switch Timer:** Displays the switch's current time
- **Daylight Saving Period:** Enter the daylight savings period.
- **Daylight Saving Offset (mins):** Configure the offset value in minutes.
- Click

[NOTE] If the configuration is not saved, it will be lost when the switch is powered off.

SNTP Configuration

SNTP Client :

Daylight Saving Time :

UTC Timezone	<input type="button" value="(GMT)Greenwich Mean Time: Dublin, Edinburgh, Lisbon, London"/>	
SNTP Server IP	<input type="text" value="0.0.0.0"/>	
Switch Timer	<input type="text"/>	
Daylight Saving Period	<input type="text" value="20040101 00:00"/>	<input type="text" value="20040101 00:00"/>
Daylight Saving Offset(mins)	<input type="text" value="0"/>	

SNTP Configuration

IP Security

IP security function grants 10 specific IP addresses permission to access the switch through a web browser for the switch management.

1. **Enable the IP Security:** Mark the check box to enable.
2. **Security IP 1 ~ 10:** Enter up to 10 specific IP Addresses.
3. Click

[NOTE] If the configuration is not saved, it will be lost when the switch is powered off.

IP Security	
<input type="checkbox"/> Enable IP Security	
Security IP 1	0.0.0.0
Security IP 2	0.0.0.0
Security IP 3	0.0.0.0
Security IP 4	0.0.0.0
Security IP 5	0.0.0.0
Security IP 6	0.0.0.0
Security IP 7	0.0.0.0
Security IP 8	0.0.0.0
Security IP 9	0.0.0.0
Security IP 10	0.0.0.0
<input type="button" value="Apply"/>	<input type="button" value="Help"/>

IP Security Interface

RSTP Configuration

The Rapid Spanning Tree Protocol (RSTP) is an evolution of Spanning Tree Protocol (STP). It provides a faster spanning tree convergence after a topology change. The switch will auto detect a device that is running STP or RSTP protocol.

System Configuration

- Modify RSTP state.
 - **RSTP mode:** Enable or disable RSTP function.
 - **Priority (0-61440):** a value used to identify the root bridge. The bridge with the lowest value has the highest priority and is selected as the root. If the value changes, the switch must be rebooted. The priority value must be multiple of 4096 according to the protocol standard rule.
 - **Max Age (6-40):** the number of seconds a bridge waits without receiving Spanning-tree Protocol configuration messages before attempting a reconfiguration. Enter a value between 6 and 40
 - **Hello Time (1-10):** The time that the control switch sends out a BPDU packet to check RSTP status. Enter a value between 1 and 10.
 - **Forward Delay Time (4-30):** The number of seconds a port waits before changing from its Rapid Spanning-Tree Protocol learning and listening states to the forwarding state. Enter a value between 4 through 30.

[NOTE]

1. Use the following rule to configure the MAX Age, Hello Time, and Forward Delay Time
 $2 \times (\text{Forward Delay Time value} - 1) > = \text{Max Age value} > = 2 \times (\text{Hello Time value} + 1)$
2. **If the configuration is not saved it will be lost when the switch is powered off.**

Rapid Spanning Tree

System Configuration	Per Port Configuration
RSTP Mode	Enable ▾
Priority (0-61440)	32768
Max Age (6-40)	20
Hello Time (1-10)	2
Forward Delay Time (4-30)	15

Priority must be a multiple of 4096
 $2 \times (\text{Forward Delay Time} - 1)$ should be greater than or equal to the Max Age.
The Max Age should be greater than or equal to $2 \times (\text{Hello Time} + 1)$.

Apply

Root Bridge Information

Bridge ID	8000001122334455
Root Priority	32768
Root Port	Root
Root Path Cost	0
Max Age	20
Hello Time	2
Forward Delay	15

RSTP– System Configuration Interface

Per Port Configuration

Configure path cost and priority of every port

- Select the port in Port column
- **Path Cost:** The cost of the path to the other bridge from this transmitting bridge at the specified port. Enter a number 1 through 200000000
- **Priority:** Network priority. Enter a number from 0 to 240. The value of priority must be a multiple of 16
- **Admin P2P:** Some of the rapid state transactions that are possible within RSTP are dependent upon whether the port concerned can only be connected to one other bridge (i.e. it is served by a point-to-point LAN segment), or whether it can be connected to two or more bridges

(i.e. it is served by a shared medium LAN segment). This function allows the P2P status of the link to be manipulated administratively. True is P2P enabling. False is P2P disabling.

- **Admin Edge:** The port directly connected to end stations cannot create a bridging loop. To configure the port as an edge port, set the port to “True” status.
- **Admin Non Stp:** The port includes the STP mathematic calculation. True does not include the STP mathematic calculation. False includes the STP mathematic calculation.
- Click

[NOTE] If the configuration is not saved, it will be lost when the switch is powered off.

Rapid Spanning Tree

System Configuration
Per Port Configuration

Port	Path Cost (1-200000000)	Priority (0-240)	Admin P2P	Admin Edge	Admin Non Stp
<div style="border: 1px solid #ccc; padding: 2px;"> Port.01 ▲ Port.02 Port.03 Port.04 Port.05 ▼ </div>	<input type="text" value="200000"/>	<input type="text" value="128"/>	<input type="text" value="Auto"/>	<input type="text" value="True"/>	<input type="text" value="False"/>

priority must be a multiple of 16

RSTP Port Status

Port	Path Cost	Port Priority	Admin P2P	Admin Edge	Stp Neighbor	State	Role
Port.01	200000	128	True	True	False	Disabled	Disabled
Port.02	200000	128	True	True	False	Disabled	Disabled
Port.03	200000	128	True	True	False	Disabled	Disabled
Port.04	200000	128	True	True	False	Disabled	Disabled
Port.05	200000	128	True	False	True	Forwarding	Root
Port.06	200000	128	True	True	False	Disabled	Disabled
Port.07	200000	128	True	True	False	Disabled	Disabled
Port.08	200000	128	True	True	False	Disabled	Disabled

RSTP – Per Port Configuration interface

X-Ring

X-Ring provides network redundancy similar to the Spanning Tree and Rapid Spanning Tree Protocols. However, recovery time is greatly reduced when the X-Ring protocol is used. The protocol identifies one switch as the Ring Master. Packets are blocked from the redundant path unless a ring member becomes disconnected from the rest of the network. When this happens, the protocol automatically restores connectivity using the redundant path.

In the X-Ring topology, every switch should enable X-Ring function and assign two member ports to the ring. Only one switch in the X-Ring group would be set as the backup switch. Other switches are called working switches and their two member ports are called working ports. If a network connection failure occurs, the backup port will automatically become a working port to recover.

The switch has a Dipswitch to configure the switch as the ring master. The ring master has the rights to negotiate and place a command to other switches in the X-Ring group. If more than one switch is in master mode, the software will select the switch with lowest MAC address number as the ring master. An LED on the front panel indicates that the switch is the ring master.

Coupling ring is used to connect 2 or more X-Ring groups providing a redundant back-up. Dual homing is used to recover from a connection loss between an X-Ring group and the upper level/core switch.

X-Ring provides a faster redundant recovery than Spanning Tree topology. The action is similar with STP or RSTP, but the algorithms not the same.

- **Enable X-Ring:** Mark the check box to enable the X-Ring function
- **1st & 2nd Working Ports:** Assign two ports as the member ports. One port will be working port and one port will be the backup port. The system will automatically decide which port is working port and which port is backup port.
- **Enable Coupling Ring:** Mark the check box to enable the coupling ring

function.

- **Coupling port:** Assign the member port.
- **Control port:** Set the switch as the master switch in the coupling ring.
- **Enable Dual Homing:** Set up one of port to be the Dual Homing port. In an X-Ring group, only one can be a Dual Homing port. This function will only work when the X-Ring function is enabled.
- Click

X-Ring

<input type="checkbox"/> Enable X-Ring	
1st Working Port	Port.01
2nd Working Port	Port.02
<input type="checkbox"/> Enable Couple Ring	
Coupling Port	Port.03
Control Port	Port.04
<input type="checkbox"/> Enable Dual Homing	Port.08

X-Ring Interface

[NOTE]

1. When the X-Ring function is enabled, the RSTP function must be disabled.
 2. **If the configuration is not saved, it will be lost when the switch is powered off.**
-

QoS Configuration

Configure QoS setting of every port

- **QoS Policy:** Select the QoS policy rule
 - **Using the 8,4,2,1 weight fair queue scheme:** The switch will follow 8:4:2:1 rate to process priority queue from Highest to lowest.. For example: the system will process 8 high queue packets, 4 middle queue packets, 2 low queue packets, and one lowest

queue packets at the same time.

- **Use the strict priority scheme:** The highest queue will always be processed first.
- **Priority Type:** Every port has 5 priority types
 - **Port-base:** The port priority will follow the **default port priority** assigned – High, middle, low, or lowest.
 - **COS only:** The port will follow the **COS priority** assigned.
 - **TOS only:** The port will follow the **TOS priority** assigned.
 - **COS first:** The port will follow COS priority first, and then another priority rule.
 - **TOS first:** The port will follow TOS priority first, and then another priority rule.
- **COS priority:** Set the COS priority level 0~7
- **TOS priority:** The system provides 0 to 63 TOS priority levels. Each level has 4 types of priority – high, mid, low, and lowest. The default value is “Lowest”. When the IP packet is received, the system will check the TOS value.

[NOTE] QoS and Rate control cannot be used simultaneously.

QoS

Qos Policy

- Use an 8,4,2,1 weighted fair queuing scheme
- Use a strict priority scheme

Priority Type:

Port.01	Port.02	Port.03	Port.04	Port.05	Port.06	Port.07	Port.08
Port-based ▾	Port-based ▾	Port-based ▾	Port-based ▾	Port-based ▾	Port-based ▾	Port-based ▾	Port-based ▾

Default Port Priority:

Port.01	Port.02	Port.03	Port.04	Port.05	Port.06	Port.07	Port.08
Lowest ▾	Lowest ▾	Lowest ▾	Lowest ▾	Lowest ▾	Lowest ▾	Lowest ▾	Lowest ▾

Apply Help

COS

Priority	0	1	2	3	4	5	6	7
	Lowest ▾	Lowest ▾	Lowest ▾	Lowest ▾	Lowest ▾	Lowest ▾	Lowest ▾	Lowest ▾

Apply Help

TOS

Priority	0	1	2	3	4	5	6	7
	Lowest ▾	Lowest ▾	Lowest ▾	Lowest ▾	Lowest ▾	Lowest ▾	Lowest ▾	Lowest ▾
Priority	8	9	10	11	12	13	14	15
	Lowest ▾	Lowest ▾	Lowest ▾	Lowest ▾	Lowest ▾	Lowest ▾	Lowest ▾	Lowest ▾
Priority	16	17	18	19	20	21	22	23
	Lowest ▾	Lowest ▾	Lowest ▾	Lowest ▾	Lowest ▾	Lowest ▾	Lowest ▾	Lowest ▾
Priority	24	25	26	27	28	29	30	31
	Lowest ▾	Lowest ▾	Lowest ▾	Lowest ▾	Lowest ▾	Lowest ▾	Lowest ▾	Lowest ▾
Priority	32	33	34	35	36	37	38	39
	Lowest ▾	Lowest ▾	Lowest ▾	Lowest ▾	Lowest ▾	Lowest ▾	Lowest ▾	Lowest ▾
Priority	40	41	42	43	44	45	46	47
	Lowest ▾	Lowest ▾	Lowest ▾	Lowest ▾	Lowest ▾	Lowest ▾	Lowest ▾	Lowest ▾
Priority	48	49	50	51	52	53	54	55
	Lowest ▾	Lowest ▾	Lowest ▾	Lowest ▾	Lowest ▾	Lowest ▾	Lowest ▾	Lowest ▾
Priority	56	57	58	59	60	61	62	63
	Lowest ▾	Lowest ▾	Lowest ▾	Lowest ▾	Lowest ▾	Lowest ▾	Lowest ▾	Lowest ▾

Apply Help

QoS configuration Interface

IGMP

The Internet Group Management Protocol (IGMP) is an internal protocol of the Internet Protocol (IP) suite. IP manages multicast traffic by using switches, routers, and hosts that support IGMP. Enabling IGMP allows the ports to detect IGMP queries and report packets and manage IP multicast traffic through the switch. IGMP has three fundamental types of messages:

Message	Description
Query	A message sent from an IGMP router or switch requesting a response from each host belonging to the multicast group.
Report	A message sent by a host indicating that the host wants to be or is a member of a given group.
Leave Group	A message sent by a host indicating that the host has is no longer a member of a specific multicast group.

The screenshot shows the IGMP configuration interface. At the top left is the 'IGMP' logo. Below it is a table with three columns: 'IP Address', 'VLAN ID', and 'Member Port'. The first row contains the values '235.080.068.083', '1', and '****5****'. Below the table are two configuration options: 'IGMP Protocol:' with a dropdown menu set to 'Enable', and 'IGMP Query :' with a dropdown menu set to 'Enable'. At the bottom are two buttons: 'Apply' and 'Help'.

IGMP Snooping interface

[NOTE] If the configuration is not saved, it will be lost when the switch is powered off.

Security Manager

Use to change the web management login user name and password.

1. **User name:** Enter the new user name (The default is “root”)
2. **Password:** Enter the new password (The default is “root”)
3. **Confirm password:** Re-type the new password
4. Click



Security Manager

User Name :

New Password :

Confirm Password :

Security Manager Interface

[NOTE] If the configuration is not saved, it will be lost when the switch is powered off.

SNMP Configuration

The SNMP is a Protocol that governs the transfer of information between management and agent. The switch supports SNMP V1.

SNMP Configuration

System Options

Name :

Location :

Contact :

Community Strings

Current Strings :

New Community String :

String :

RO RW

Trap Managers

Current Managers :

New Manager :

IP Address :

Community :

Trap version: v1 v2c

SNMP Management interface

System Options

- **Name:** Enter a name for the switch
- **Location:** Enter the switch physical location
- **Contact:** Enter the name of contact person or organization

Community strings

Serve as a password.

- **Strings:** Enter the name of the string
- **RO:** Read only. Enables requests accompanied by this string to display MIB-object information
- **RW:** Read write. Enables requests accompanied by this string to display MIB-object information and to set MIB objects
- Click

Trap Manager

A trap manager is a management station that receives traps (the system alerts generated by the switch). If there is no trap manager defined, traps will not be issued. Create a trap manager by entering the IP address of the station and a community string.

- **IP Address:** Enter the trap device IP
- **Community Strings:** Enter The trap device community strings
- Click

Configuration Backup

Used to backup the configuration to a TFTP server and load the backup configuration from the TFTP server.

TFTP Restore Configuration

Restore the ROM value from the TFTP Server.

- **TFTP Server IP Address:** Enter the TFTP server IP.
- **Restore File Name:** Enter the file name.
- Click

The screenshot shows a web interface titled "Configuration Backup". It has two tabs: "TFTP Restore Configuration" (selected) and "TFTP Backup Configuration". Below the tabs are two input fields: "TFTP Server IP Address" with the value "0.0.0.0" and "Restore File Name" with the value "data.dat". At the bottom are "Apply" and "Help" buttons.

TFTP Restore Configuration interface

TFTP Backup Configuration

Save current flash ROM value to the TFTP server.

- **TFTP Server IP Address:** Enter the TFTP server IP
- **Backup File Name:** Enter the file image name
- Click

Configuration Backup

TFTP Restore Configuration | TFTP Backup Configuration

TFTP Server IP Address: 0.0.0.0

Backup File Name: data.dat

Apply Help

TFTP Backup Configuration interface

TFTP Update Firmware

Use to update firmware. Ensure the TFTP server is ready and the firmware image is stored on the TFTP server.

- **TFTP Server IP Address:** Enter the TFTP server IP
- **Firmware File Name:** Enter the name of firmware image
- Click

TFTP Update Firmware

TFTP Server IP Address: 192.168.16.2

Firmware File Name: image.bin

Apply Help

TFTP Update Firmware interface

Factory Default

Reset the Switch to the default configuration. **NOTE: The IP Address, subnet mask, default gateway, username, and password will remain as configured by the user.**

- Click



Factory Default interface

System Reboot

Reboot the Switch

- Click



System Reboot interface

Save Configuration

Save the configuration to flash memory. If the switch is powered off without saving the configuration, all changed configuration will be lost.

- Click 



Save Configuration Interface

Rate Control

Set up every port's bandwidth rate and packet limitation type

- **Limit Packet type:** Select the packet type to filter. The packet types have are all packet types, broadcast/multicast/unknown unicast packets, broadcast/multicast packets, and broadcast packet only. The broadcast/multicast/unknown unicast packet, broadcast/multicast packet, and broadcast packet only are only for ingress. The egress rate only supports all packet types.
- **Band Width:** Ports 1 through 8 support port ingress and egress rate control. For example, assume port 1 is 10Mbps, users can set its effective egress rate to 1Mbps, and the ingress rate to 500Kbps.
 - **Ingress:** Select the port effective ingress rate. The valid range value is 1MB, 2MB, 4MB, 8MB, 16MB, 32MB and 64MB. The default value is "disable"
 - **Egress:** Select the port effective ingress rate. The valid range value is 128kbps, 256Kbps, 512Kbps, 1MB, 2MB, 4MB, and 8MB. The default value is "disable."

- Click 

Rate Control

	Limit Packet Type	Ingress	Egress for All
Port.01	Broadcast/Multicast/Unknown Unicast ▾	Disable ▾	Disable ▾
Port.02	Broadcast/Multicast/Unknown Unicast ▾	Disable ▾	Disable ▾
Port.03	Broadcast/Multicast/Unknown Unicast ▾	Disable ▾	Disable ▾
Port.04	Broadcast/Multicast/Unknown Unicast ▾	Disable ▾	Disable ▾
Port.05	Broadcast/Multicast/Unknown Unicast ▾	Disable ▾	Disable ▾
Port.06	Broadcast/Multicast/Unknown Unicast ▾	Disable ▾	Disable ▾
Port.07	Broadcast/Multicast/Unknown Unicast ▾	Disable ▾	Disable ▾
Port.08	Broadcast/Multicast/Unknown Unicast ▾	Disable ▾	Disable ▾

Rate Control Interface

[NOTE]

1. If the configuration is not saved, it will be lost when the switch is powered off.
 2. QoS and Rate control cannot exist at the same.
-

System Log

Set up system log events and view the system log events

System Log

Use to view the system events.

- Click button to get newest system log event
- To clear the log events, click
- Drag down the page list to switch to a different page.
- **System Log Client Mode:** Select Client Only, Server Only, or Both
- **System Log Server IP:** Assign the system log server IP
- Click

System Log

System Log Configuration

Event Configuration

System Log Mode Client Only

System Log Server IP 0.0.0.0

Apply

1: Jan 1 00:08:50 : System Log Enable!

Page.1

Reload Clear

System Log Configuration interface

Event Configuration

Select the system log events. When a selected event occurs, the system will log the information.

- **System event selection:** 4 selections – Cold start, Power status, SNMP Authentication Failure, and X-Ring topology change. Mark the checkbox to select the event.
 - **Device cold start:** A log entry will be made when the switch is cold started.
 - **Power status:** A log entry will be made when the power status changes. (i.e. power source one becomes unavailable).
 - **SNMP Authentication Failure:** A log entry will be made when an SNMP Authentication Failure occurs.

- **X-Ring topology change:** A log entry will be made when the X-Ring topology changes.
- **Port event selection:** Select port specific events to log. 3 selections – Link UP, Link Down, and Link UP & Link Down.
 - **Link UP:** The system will produce a log message when the port comes up.
 - **Link Down:** The system will produce a log message when the port connection goes down.
 - **Link UP & Link Down:** The system will produce a log message when port the port goes down and comes up.
- Click

System Log

System Log Configuration		Event Configuration	
System event selection			
<input type="checkbox"/> Device cold start	<input type="checkbox"/> Power status		
<input type="checkbox"/> SNMP Authentication Failure	<input type="checkbox"/> X-ring topology change		
Port event selection			
Port.01	Disable <input type="button" value="v"/>	Port.02	Disable <input type="button" value="v"/>
Port.03	Disable <input type="button" value="v"/>	Port.04	Disable <input type="button" value="v"/>
Port.05	Disable <input type="button" value="v"/>	Port.06	Disable <input type="button" value="v"/>
Port.07	Disable <input type="button" value="v"/>	Port.08	Disable <input type="button" value="v"/>
<input type="button" value="Apply"/> <input type="button" value="Help"/>			

Trouble shooting

- Verify the power supply is correct (12 to 48 VDC). Do not exceed 48 VDC.
- Ensure the proper cable is used for RH-45 connections: 100Ω Category 3, 4, or 5 cable for 10Mbps connections or 100Ω Category 5 cable for 100Mbps connections. Ensure the length of any twisted-pair connection does not exceed 328 feet (100 meters).
- LED Indicators assist in identifying problems.

Technical Specifications

The 6 10/100TX plus 2 100FX with X-Ring managed industrial switch technical specification is following.

Standard	<p>IEEE 802.3 10Base-T Ethernet</p> <p>IEEE 802.3u 100Base-TX and 100Base-FX Fast Ethernet</p> <p>IEEE802.3x Flow Control and Back-pressure</p> <p>IEEE802.1d spanning tree / IEEE802.1w rapid spanning tree</p> <p>IEEE802.1p class of service</p> <p>IEEE802.1Q VLAN Tag</p>
Protocol	CSMA/CD
Management	<p>SNMP management</p> <p>Web interface management</p> <p>One default button for system default setting</p>
SNMP MIB	<p>RFC 1213 MIBII</p> <p>RFC 1493 Bridge MIB</p> <p>RMON RFC 1757</p> <p>RFC 2674 VLAN MIB</p> <p>RFC 1643 Ethernet like MIB</p> <p>RFC 1215 Trap MIB</p> <p>Private MIB for switch information, X-Ring, port alarm, TFTP firmware upgrade, reset, port mirror, IP security management, IGMP management MIB.</p>

SNMP Trap	<p>Up to 3 Trap stations</p> <p>Cold start</p> <p>Port link Up</p> <p>Port link down</p> <p>Authentication Failure</p> <p>Private Trap for power status</p> <p>Port Alarm configuration</p> <p>Fault alarm, X-Ring</p>
Technology	Store and forward switching architecture
Transfer Rate	<p>14,880 pps for 10Base-T Ethernet port</p> <p>148,800 pps for 100Base-TX/FX Fast Ethernet port</p>
Transfer packet size	64bytes to 1522 bytes (with VLAN tag)
Packet filter	<p>4 types of packet filter rule with different packet combination:</p> <ul style="list-style-type: none"> ■ All of packet ■ Broadcast/ multicast/ unknown unicast packet ■ Broadcast/ multicast packet ■ Broadcast packet only
MAC address	2K MAC address table
Memory Buffer	1Mbits
LED	<p>Per port: Link/Activity (Green), Full duplex/Collision (Yellow)</p> <p>Per unit: Power (Green), Power 1 (Green), Power 2 (Green), Fault (Yellow), Master (Green)</p>

Network Cable	<p>10Base-T: 2-pair UTP/STP Cat. 3, 4, 5 cable EIA/TIA-568 100-ohm (100m)</p> <p>100Base-TX: 2-pair UTP/STP Cat. 5 cable EIA/TIA-568 100-ohm (100m)</p>
Optical cable	<ul style="list-style-type: none"> ■ SC (Multi-mode): 50/125um or 62.5/125um ■ SC (Single mode): 9/125um ■ Available distance: 2KM (Multi-mode) / 30KM (single-mode) ■ Wavelength: 1310nm (multi-mode/ single mode)
Back-plane	1.6Gbps
Packet throughput ability	1.19Mpps @64bytes
Power Supply	<p>12 ~48 VDC</p> <p>Redundant power with polarity reverse protects function and connective removable terminal block for master and slave power.</p>
Power consumption	7.68 Watts
X-Ring	<p>2 ports for X-Ring to provide redundant backup feature and the recovery time below 300ms and start by Web interface management. The ring port can be defined by Web interface.</p>
VLAN	<p>Port based VLAN</p> <p>IEEE802.1Q Tag VLAN.</p> <p>Both of port based and Tag based VLAN group up to 64 VLANs.</p>

Class of service	IEEE802.1p class of service Per port provides 4 priority queues.
Quality of service	The quality of service determined by port, Tag and Ipv4 Type of service.
Spanning tree	IEEE802.1d spanning tree IEEE802.1w rapid spanning tree.
IGMP	IGMP v1 and Query mode Up to 256 groups.
SMTP	Supports SMTP Server and 4 e-mail accounts for receiving event alert
SNTP	Support SNTP to synchronize system clock in Internet
Management IP security	IP address security to prevents unauthorized intruder
Port mirror	TX packet only Both of TX and RX packet
Firmware update	TFTP firmware update TFTP backup and restore
Alarm	Relay output for port breakdown and power source failure. Alarm Relay Contact Rating: 1A @ 24VDC Contacts normally open

Bandwidth control	<ul style="list-style-type: none"> ■ Ingress packets filter and egress packet limit. ■ The egress rate control supports all of packet type and the limit rates are 128kbps, 256Kbps, 512Kbps, 1MB, 2MB, 4MB, and 8MB. ■ Ingress filter packet type combination rule for Broadcast/Multicast/Unknown Unicast packet, Broadcast/Multicast packet, Broadcast packet only and all of packet. ■ The ingress packet filter rate can be set follow as:1Mbps · 2Mbps · 4Mbps · 8Mbps · 16Mbps · 32Mbps · 64Mbps.
DHCP client	DHCP client function to obtain IP address from DHCP server
Install	DIN rail kit and wall mount ear for wall mount or DIN-type cabinet install
Operation Temp.	Wide Operating Temp. Model: -40°C to 75°C (-40°F to 167°F)
Operation Humidity	5% to 95% (Non-condensing)
Storage Temperature	-40°C to 85°C
Case	IP-30
Dimensions	2.3 x 5.7 x 4.4 in (5.8 x 14.5 x 10.9 cm)
EMI	FCC Class A, CE EN61000-4-2 (ESD), CE EN61000-4-3 (RS), CE EN-61000-4-4 (EFT), CE EN61000-4-5 (Surge), CE EN61000-4-6 (CS), CE EN61000-4-8, CE EN61000-4-11, CE EN61000-4-12, CE EN61000-6-2, CE

	EN61000-6-4
Safety	UL cUL CE/EN60950-1
Stability testing	IEC60068-2-32 (Free fall) IEC60068-2-27 (Shock) IEC60068-2-6 (Vibration)